

1		2		3		4		5		6	
PIN NO.	SYMBOL	REV	DESCRIPTION:	DATE							
1	Vss	A00	First issue	MARCH-10-2007							

1	Vss
2	Vdd
3	Vo
4	RS
5	R/W
6	E
7	DB0
8	DB1
9	DB2
10	DB3
11	DB4
12	DB5
13	DB6
14	DB7
15	A/Vee
16	K

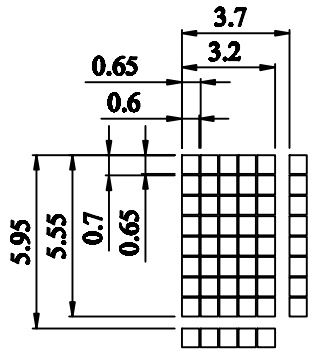
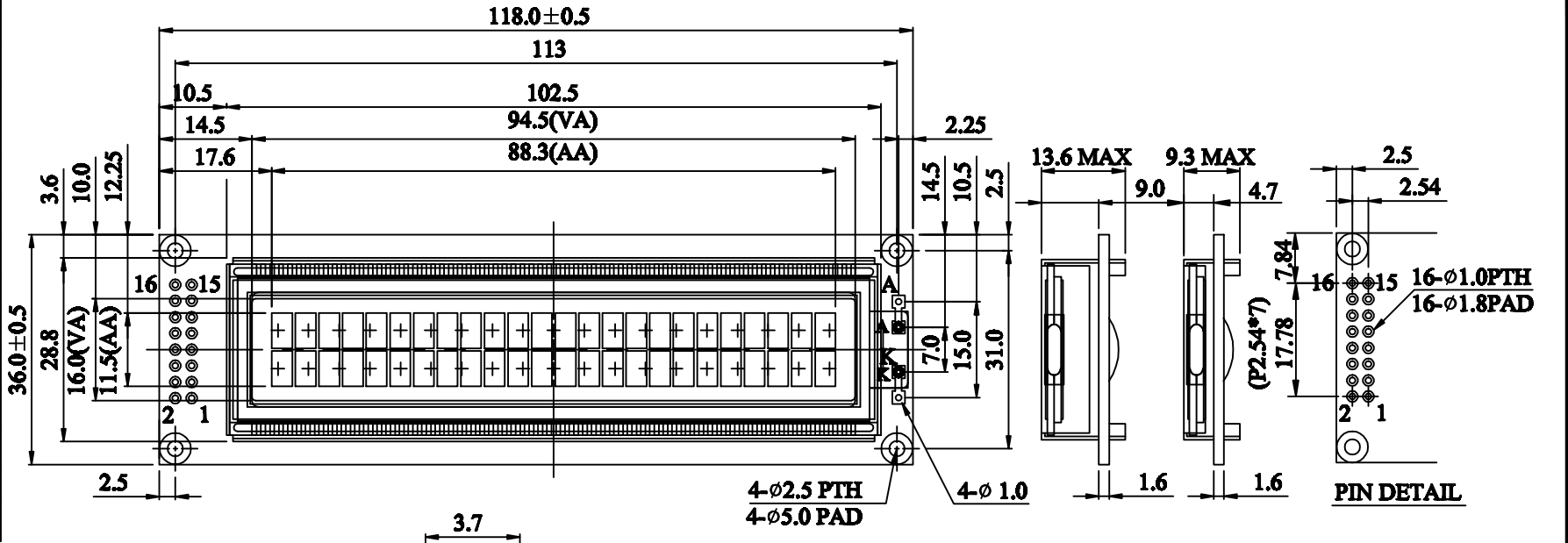

↑  
VIEWING DIRECTION

LED B/L EL or NO B/L

The tolerance of non-specified dimension is ±0.3mm.

SPECIFICATIONS

STORAGE TEMP : -30°C TO +80°C  
 OPERATING TEMP : -20°C TO +70°C  
 VIEWING DIRECTION : 6 O'CLOCK  
 DRIVE CONDITION : 1/16 DUTY, 1/5 BIAS, VLCD= 4.2V  
 DISPLAY MODE : STN(Y/G) TRANSFLECTIVE P MODE  
 BACK LIGHT ITEM: Y/G;4.1V  
 LCM OPERATING VOLTAGE:5.0V  
 CONTROLLER/DRIVER IC: ST7066U

DOT SIZE  
SCALE 5/1

DESCRIPTION:		<b>C/D DEMENSION</b>	
SCALE: FT	深圳市兴宇合电子有限公司		
SHEET: 1 OF 1			
GENERAL TOL: ±0.20mm	UNIT: mm		
APPROVALS	DATE	MODEL NUMBER:	PART NO:
APP:		JBC2402A00-00Y	
CHK:			
DWN: ZY.CHEN	MAR-10-07	DO NOT SCALE THIS DRAWING.	PROJECTION

A

A

B

C

D

D

1

2

3

4

5

6